

TECHNO MODULE

MODULAR  
**ELSTEEL**  
ENCLOSURES



# INTRODUCTION

**ELSTEEL is a world leader in the design, development and manufacture of modular panel enclosures.**

This is built on a strong foundation of 30+ years of operations supported by continual investment in research and development. Our objective is as simple as our products: To manufacture the world's best enclosures at the best possible price.

ELSTEEL delivers enclosure solutions for every build. Whether it is a small Terminal Box or the largest custom designed distribution panel for an Olympic Size Stadium, ELSTEEL delivers the solution.



You're holding a top of the line quality product in your hands. Made with love and excellence! I hope you will enjoy assembling and using Elsteel products as much as I enjoy manufacturing it for you.

A stylized, handwritten signature in black ink.

**Fang Logstrup**  
Managing Director





## **TECHNO MODULE**

Techno Module is a patented 200 mm grid modular system for the switchboard manufacturing industry, fully type tested in accordance with IEC 61439-2.

It is the result of many years work in research and development and continuous testing at recognised test stations around the world.

Techno Module is an open system that can accommodate all major brands of breakers, contactors, relays etc.

# THE TECHNO MODULE DESIGNER

## Panel properties

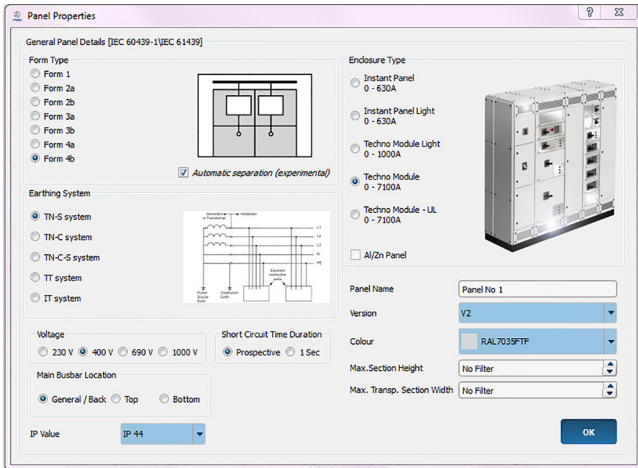

## 2D view

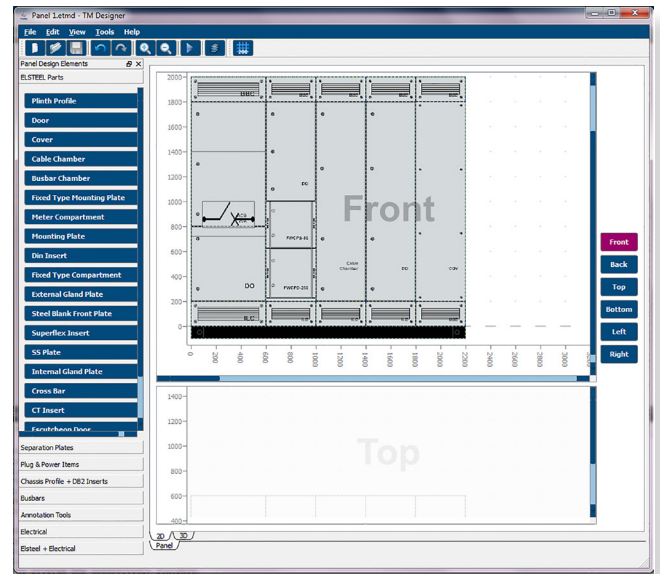

## 3D view

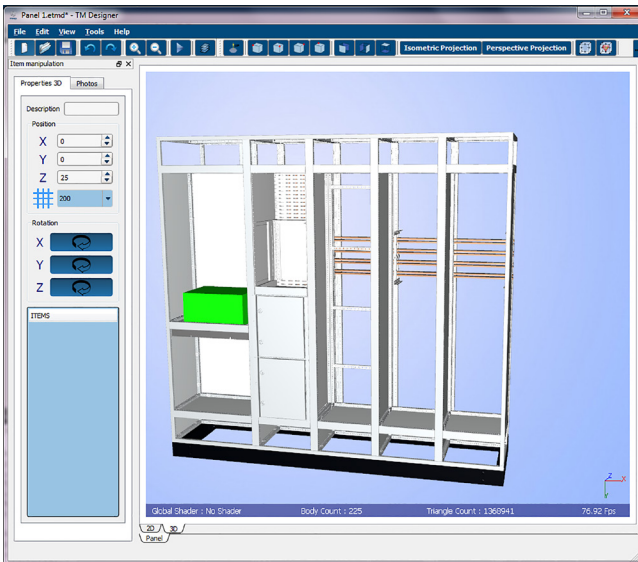

## 3D view

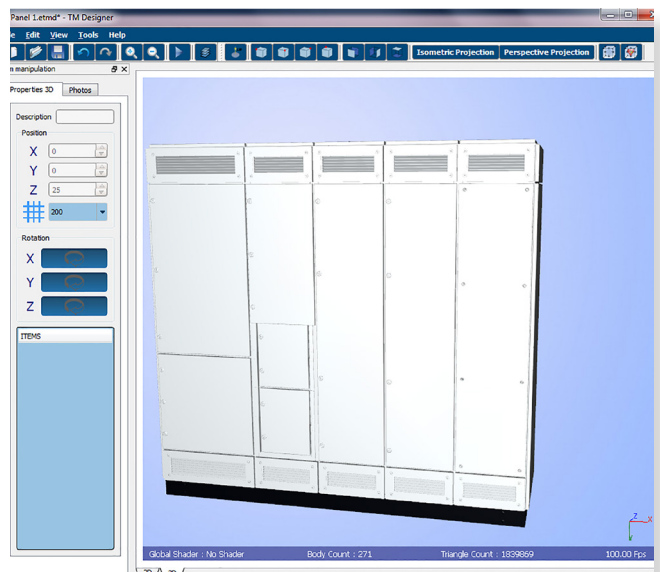

**The first step in designing a successful distribution board or motor control centre is planning with Techno Module Designer (TMD).**

Panel builders spend a lot of time quoting projects with a success rate as little as 5-10%. So In order to save engineers precious time and allow them to spend more time with the customers, we have created a unique tool. Within 15 minutes you can draw a panel board and get a BOM including copper and electrical items. Its fast and its free!

Another great feature is the software creates 3D drawings for each panel. View in TMD or export into other 3D software packages. You can then plan site wide busbar routes for example.

Spend less time calculating and more time selling.

# FRAME WORK

**The Techno Module system is modular in steps of 200 mm in all three directions.**

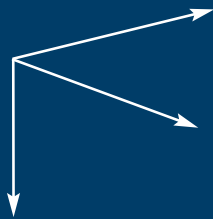

That means that there is no limit to the possibilities and positions.

The strong framework is made from 2 mm electro galvanised powder coated steel profile.

It forms a 25 mm grid and can be arranged in an unlimited number of ways.

It rests on a modular base frame which incorporates all facilities for dividing and transportation.

Smaller panels up to 1250 Amps can be built in the economical Techno Module Light.



# BUSBARS

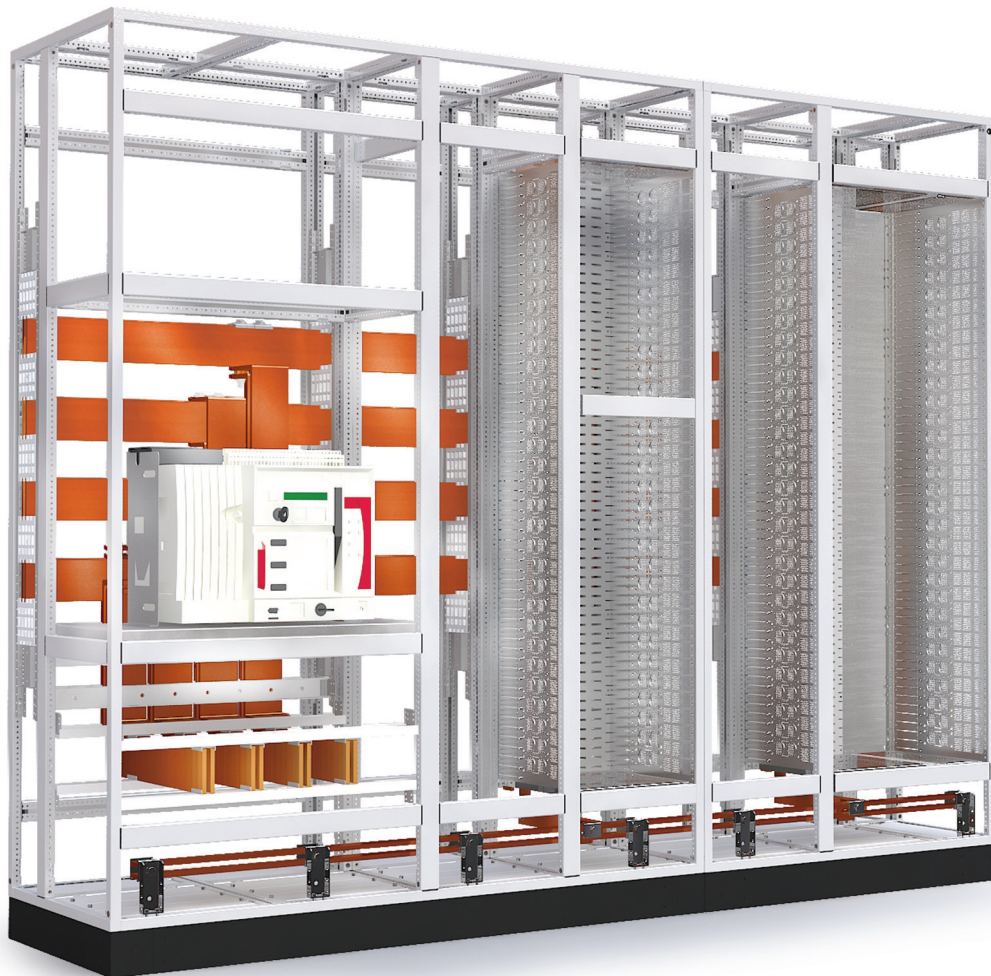



**Busbar systems use standard  
'off the shelf' 10mm flat bars.**

Either copper or aluminium.

The busbar holders are made from specially formulated re-enforced self extinguishing plastic and can be mounted in any position within the framework.

During countless type-testing, up to 7100 A 100 kA / 3 s and 120 kA / 1 s, the busbar systems and holders have been tested rigorously again and again.

Busbar connections are a clamp arrangement, this allows the bars to slide during increase and decrease in temperature. This eliminates the risk of lose connections and of debris in your panel.

# PLUG & POWER

**Plug & Power is a revolutionary way of making distribution boards and motor control centres.**

The panel board can be rearranged indefinitely while still supplying power to your existing equipment.

Both consultants and end-users have to accommodate the rapid development in medical equipment, CNC machines and process plants etc, during new investments in construction.

With Plug & Power, consultants are no longer tied to strict specifications.

Last minute modifications can be made at any point during assembly, installation or operation.

Shut-down and out-of-hour labour costs for modifications are now a thing of the past.



**Patented**

# PLUG & POWER

**Removable units** - when you need to add or replace a breaker on a live panel!

Incoming connections are plug type.

Outgoing connections are fixed type.

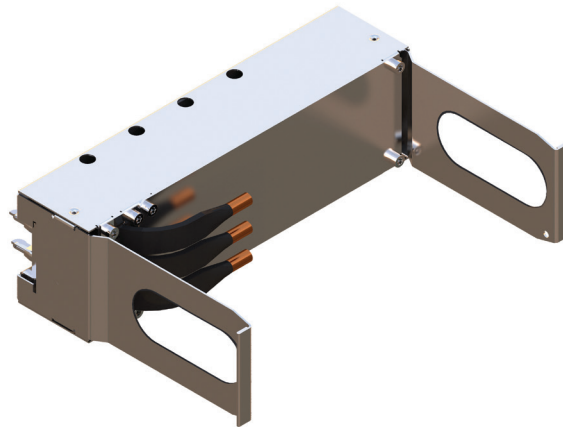

## Specifications of Plug-in

Design verified IEC 61439

Arc fault IEC 61641

Any unit size, fitted anywhere in the system

No tools needed for insertion or removal of units

New breakers can be added anywhere in the panel

Fastest way of construction due to pre-assembled units

Locked position without screws

Breakers or starters can be replaced

Outgoing cable termination can be left or right

Fully insulated busbar optional

Dual purpose, breaker or motor starter

Plugs directly to the busbar

Any breaker brand can be used

5 pole incoming

Direct on Line or Star Delta Starter

Busbar rating 80 kA / 1 sec.

Delivered as a fully assembled unit

**Fully Withdrawable Units** - Enables fast replacements in an emergency reducing production downtime to the very minimum possible!

Incoming connections are plug type.

Outgoing connections are plug type.

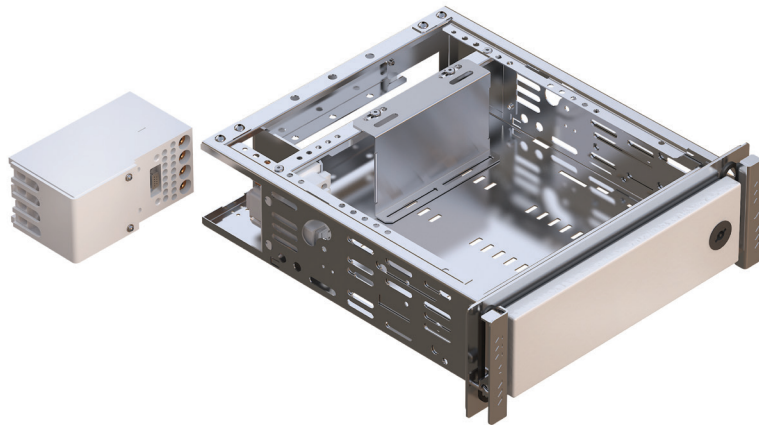

## Specifications of Withdrawables

Design verified IEC 61439

Arc fault IEC 61641

Any unit size, fitted anywhere in the system

All cables are terminated in the side cable compartment

No tools needed for insertion or removal of units

A unit is replaced in seconds!

Heavy duty SS handles and mechanism

Insert, operate, test and release functions, all in one handle.

All electrical components can be 'lifted' out of the units

Plugs directly to the busbar

Safety lock while removing the unit

Optional shutters

Outgoing terminations can be left or right.

Lockable in 'on' and 'service' position

Fully insulated busbar optional

Any breaker brand can be used

5 pole incoming

Direct on Line or Star Delta Starter

Busbar rating 80 kA / 1 sec.

MODBUS or PROFIBUS intelligent communication.

Delivered as a fully assembled unit

# PLUG & POWER

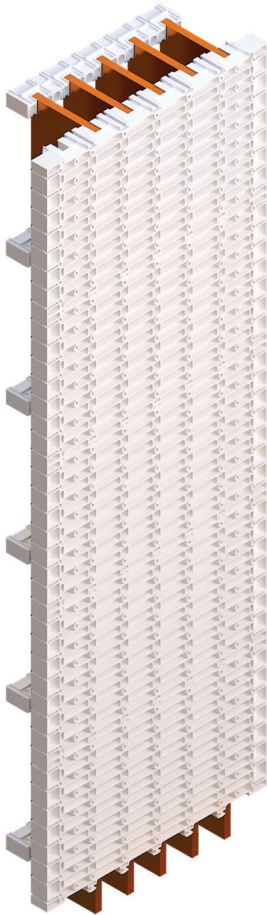

The vertical busbars are mounted in a flat holder which doubles as a form 4 separation plate and plug-in base. We call it the motherboard. These motherboards are mounted from top to bottom in each section, allowing connections with the bus bars wherever you choose to insert the withdrawable or removable units.

Each section can carry 1250 Amps, allowing sufficient space for extra units once the panel is installed.

When designing your future Plug & Power panel, we recommend having at least 30% free space for expansion. For example - that extra scanner at the hospital, the new shop unit at the mall, an additional factory compressor, or an extra pump on the oil platform. With Plug & Power, it's now easy and quick to add these later, without impacting the production!

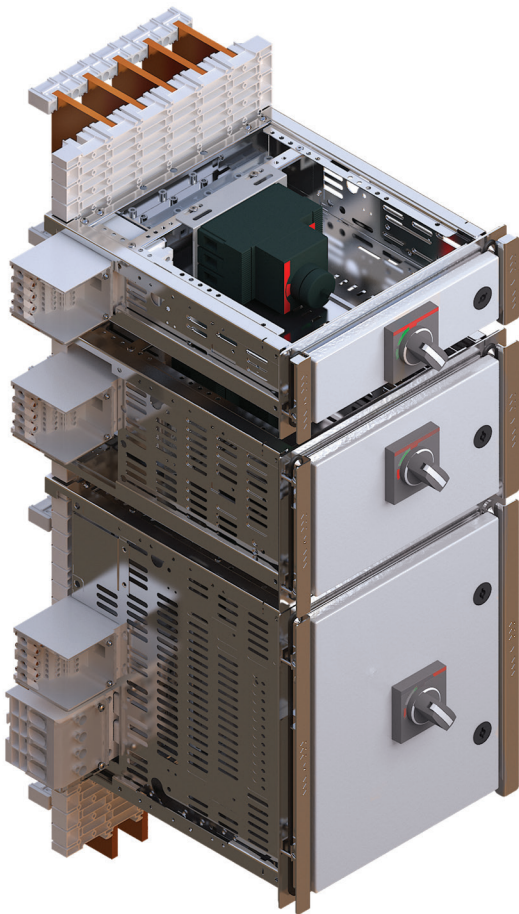

You have the freedom to **Plug in** and **Power up** anything you need, anywhere you like in the panel, at any given time.

**Plug & Power** has furthermore been designed for quick and easy assembly, saving not only the panel builder a considerable amount of time in the workshop by simply 'plugging-in', but also the company a huge expense. Outgoing distribution or motor starter units can be conveniently pre-assembled on a worktable.

\* Plug & Power is patented and a registered trade name owned by Elsteel.

# FORM 3 + 4

**Highest forms of personal safety as well as protection of materials and environment.**

When built in accordance with this standard, it is possible to work in one section of the panel while the rest of the pane is still live.

Internal separation plates prevent foreign objects or particles from transferring from one section of the panel to another (resulting in a short circuit in a compartment that may be live). This prohibits the whole panel from becoming contaminated and complete panel damage.





# ARC FAULTS



**Arc Filters have been included in the design of the separation plate. Once you install the standard chimneys your enclosure is arc safe.**

With arc filters fitted, flames, gases or solid objects are prevented from escaping from the front or side of the panel, where the operator may be standing.

# TESTING + FINISH

**Each and every panel is tested by the panel builder/integrator in accordance with specifications from the Constructors Manual, and the routine test specified in IEC 61439-1, before shipment.**

The surface of the panel is powder coated in RAL 7035 fine textured finish. It's easy to maintain and will look 'as new' for many years.

Phosphated and chrome-passivated pretreatment makes the panel suitable for tough climates and conditions. Degree of protection up to IP55.

After commissioning, the panel is easily expanded and breakers or motor starters can be removed or fitted while it is live.





# CERTIFICATION

Elsteel Techno Module System is certified as per IEC and UL standards by independent certification authorities.



Elsteel Techno Module System is fully type tested as per IEC 61439-1, IEC 61439-2 and IEC TR 61641 with the following brands.



Elsteel Techno Module System is certified for marine applications by



# TECHNICAL SPECIFICATION

## GENERAL DATA

<b>Applications</b>	Low voltage power switchgear and control gear assembly: Power Distribution Centres, Motor Control Centres, PLC & DCS Switchboards
<b>Installation</b>	Indoor
<b>Mounting possibilities</b>	Floor standing / Wall mounting
<b>Panelling standard colour</b>	RAL 7035 Fine Textured (Non-standard colours by request)
<b>Coating</b>	Epoxy/ Polyester Powder, thickness $\geq 60\mu\text{m}$

## MECHANICAL DATA

<b>Field / Tier Arrangement</b>	Front connected / Back to back
<b>Cable entry</b>	Top / Centre / Bottom
<b>Compartment types</b>	Fixed, Removable & Fully withdrawable
<b>Access</b>	Front / Rear
<b>IP rating</b>	IP43, IP44, IP54, IP55 (refer CM page 6:24)
<b>IK rating</b>	IK08, IK10 (refer CM page 6:24)
<b>Form of segregation</b>	1, 2a, 2b, 3a, 3b, 4a, 4b / Form 4 type 1-7
<b>Maximum dimensions of a transport section (Basic module 200×200×200)</b>	Width - 2400 Height - 2400 (can be extended) Depth - 2400
<b>Material &amp; paint specifications</b>	(refer CM page 6:40, 6:41)

## ELECTRICAL DATA

<b>Rated operational voltage (Ue)</b>	415V / 690V / 1000V
<b>Rated insulation voltage (Ui)</b>	690V / 1000V
<b>Rated frequency (f)</b>	50Hz
<b>Rated impulse voltage (Uimp)</b>	Up to 12 kV
<b>Rated current (In) for TM panels</b>	Up to 7100A (refer CM page 6:06)
<b>Rated current (In) for TM Light panels</b>	Up to 1000A (refer CM page 6:06)
<b>Rated short time current (Icw)</b>	Up to 120kA / 1s & 100kA / 3s (refer CM page 6:07)
<b>Pollution degree</b>	3
<b>Min. clearance</b>	(refer CM page 6:13)
<b>Earthing system</b>	TN-C, TN-S, TN-C-S, TT, IT (refer CM page 6:28)

## BUSBAR HOLDER DATA

Type	Thermal Class (IEC 60085)	CTI (IEC 60112)	Material Group
BAH	Thermal Class B	175	IIIa
SLBH	Thermal Class F	600	I
UBH	Thermal Class B	175	IIIa
OMH	Thermal Class B	175	IIIa
BH	Thermal Class F	600	I
MAB	Thermal Class B	175	IIIa
MABHT	Thermal Class F	600	I
DRHU	Thermal Class F	600	I
INS	Thermal Class B	175	IIIa
NEU	Thermal Class B	175	IIIa
FCSH	Thermal Class B	175	IIIa
MBO	Thermal Class B	175	IIIa
RBH	Thermal Class B	175	IIIa

For more certifications and latest updates please see [www.elsteel.com](http://www.elsteel.com)



# MATERIAL SPECIFICATION

Base Frame	2 mm mild steel powder coated in black (RAL 9005)
Corners	Aluminium die casted powder coated in Light grey (RAL 7035) Fine tex.
Corner Bar / Cross Bar	Electro galvanized 2 mm powder coated in Light grey (RAL 7035) Fine tex.
	Stainless steel 1.5 mm (AISI 304, AISI 316) Wet grinding (180)
Doors / Covers	Mild steel 1.5 mm powder coated in Light grey (RAL 7035) Fine tex.
Doors with window	Mild steel 1.5 mm powder coated in Light grey (RAL 7035) Fine tex. &
	4 mm Tempered Tinted glass
Door Stabilisor	Mild steel 20×20×1.5 square pipe powder coated in Light grey (RAL 7035) Fine tex.
Door with cable glands	Mild steel 1.5 mm powder coated in Light grey (RAL 7035) Fine tex.
Mounting Plate	Mild steel 2 mm powder coated white (RAL 9010) / 2 mm Alu-zinc
Separation Plates	Mild steel (2×2, 2×4, 2×6, 4×4, 4×6,) 1 mm painted white (RAL 9010)
	All other sizes 1.2 mm
Flat Cover	Mild steel 1.5 mm painted in Light grey (RAL 7035) Fine tex.
Panel Assembly Kit	Mild steel 3 mm zinc plated
Cable Holder	Mild steel 1.5 mm painted white (RAL 9010) for up to 600 mm and Mild steel 2mm
	painted white (RAL 9010) for 600 mm & above
Lifting Eyes (14380)	Mild steel 3 mm powder coated in black (RAL 9005)
Lifting Eyes (14390)	Mild steel 3 mm zinc plated
Wall Mounting Brackets	Mild steel 3 mm powder coated in Light grey (RAL 7035) Fine tex.
Transport Wheel Holder	Mild steel 3 mm powder coated in black (RAL 9005)
Busbar Holder	
Fish Plate	Self extinguishing fibre material / reinforced PC
H to V connectors	Copper 10 mm
Busbar tap off - 21000	Copper 10 mm
- 21010 & 21020	Dia 10 mm zinc plated
- 21030	Copper 5 mm
Bracket for earth conductor	Mild steel 3 mm zinc plated
Copper Spacer	Mild steel 3 mm zinc plated
	Copper Dia 30
Instant Panel - Casing	
- Doors	Mild steel 1.5 mm powder coated in Light grey (RAL 7035) Fine tex.
- Mounting Plate	Mild steel 1.5 mm powder coated in Light grey (RAL 7035) Fine tex.
	Mild steel 2 mm powder coated in white (RAL 9010) / Alu-zinc 2 mm

## COPPER SPECIFICATIONS

Electrolytic Copper high conductivity OC-ETP 99.98 % JIS H3140 C 1100 Tempered upto half hard.

For more certifications and latest updates please see [www.elsteel.com](http://www.elsteel.com)

# PAINT SPECIFICATION

## 1. Standard Paint

### Degreasing and Phosphating

- By the spray method at approx. 47°C
- Cleaning and passivating of the surface
- Coating with phosphate (coat thickness approx. 1 µm)

### Textured Powder Coating

- Electrostatic coating
- Raw material: Epoxy Polyester
- Can be readily overpainted
- Can be decontaminated
- High mechanical strength
- Good resistance to chemicals and UV rays coat thickness  $\geq 70$  µm

### Smooth Powder Coating

- Electrostatic coating
- Raw material: Epoxy Polyester
- Can be readily overpainted
- Can be decontaminated
- High mechanical strength
- Good resistance to chemicals and UV rays coat thickness  $\geq 60$  µm

### Corrosion resistance according to IEC 62208 clause 9.13.1 and IEC 61439-2 clause 10.2.2.2

#### Severity test A

- 6 cycles of 24h each damp heat cycling test according to IEC 60068-2-30 (Test Db) at  $(40 \pm 2)$  °C and relative humidity of 95%
- 2 cycles of 24h each to salt mist test according to IEC 60068-2-11 (Test Ka: salt mist) at a temperature of  $(35 \pm 2)$  °C

Summary: No signs of rust, suitable for harsh industrial surrounding (Indoor installation)

## 2. Resistance

The standard coating is resistant to:

- Mineral oils
- Lubricants
- Machining emulsions
- Solvents (briefly, such as during cleaning processes)

The standard coating is suitable for a continuous temperature of -40°C to +90°C.

The standard coating can withstand a continuous temperature of 45°C to 85% RH.

### Please Note

If UV resistant powder coating is required it has to be mentioned as a special requirement. The standard coating is not UV Resistant. IP protection categories do not imply that enclosures are suitable for outdoor applications.

## 3. Overpainting

After careful cleaning and perhaps slight roughening of the surface, the standard coating can be overpainted with Powder coating.

\*Powder Coating System : Electrostatic Powder Coating System (ITW Gema – Switzerland)

\*Pretreatment System : Five stage, Phosphate free Conversion Coating system (Henkel Germany)

For more certifications and latest updates please see [www.elsteel.com](http://www.elsteel.com)

# REFERENCES

Customer	Product	Country
Olympic Stadium	Main Distribution Panel	Australia
British Aerospace	Main Distribution Panel	Australia
Colt Telecom	Techno Module	Belgium
NATO Headquarters	Techno Module MCC	Belgium
Ministry of Defence	Motor Control Center	Dubai
Giga Gold Refinery	2500A LV Panels	Dubai
Jebel Ali Air Port	Main Distribution	Dubai
Nordbahnhof Berlin	NSHV and GHV	Germany
Alcatel Stuttgart	NSHV and GHV	Germany
National Hospital	4000A Switchboard	Iceland
Eskifjord Ltd	2500A Switchboard	Iceland
Hyundai Motor India Ltd	Techno Module	India
Nokia Mobile Phone Facility Project	Techno Module	India
Toyota Kirloskar Motor Pvt Ltd	PCC Panels - Techno Module	India
Radisson Hotel	Techno Module/ Form 4	Jordan
Amman East Station	Form 4 Motor Control Center D/O	Jordan
Central Bank of Kenya	Main Board/ Sub Boards	Kenya
Commercial Bank of Africa	Main Board/ Sub Boards	Kenya
Multilinx Factory	Distribution Boards	Maldives
SAVANNAH Sugar Estate	Techno Module and MCC	Mauritius
Ulvesund Elektro AS	1600A Main Panels	Norway
Power Plant Mar Kraftverk	Motor Control Center	Norway
Qatar International Stadium	Distribution Panel	Qatar
West Bay Cooling System - Phase 1	Form 4 Panel 7000A	Qatar
SAB Miller Beer Factory	Motor Control Center WWT Plant	Romania
Hydro Tech Engineering	Motor Control Center WWT Plant	Romania
Esso Deepwater Ltd	Generator Control Panel	Singapore
Shang Ri La Hotel	Techno Module	Singapore
Greenpoint Stadium (2010 World Cup)	Techno Module	South Africa
Coca Cola Dar Es Salaam	Techno Module	South Africa
Barcelona Air Port	Form 4 Motor Control Center	Spain
Jerez Air Port	Form 4 Motor Control Center	Spain
Manchester Air Port	Form 4 Motor Control Center	UK
Nokia	Main Switchboard	UK
International Air Port Doha	Techno Module MCC	UAE
Fujairah	Techno Module MCC	UAE
Brodosplit Shipyard	Marine Panel 6300A	Croatia

For more certifications and latest updates please see [www.elsteel.com](http://www.elsteel.com)

## EUROPE

**Cebco - Czech Republic**  
Tel: +420 604 645 648  
Mail: info@cebco.cz  
Mail: cebco@seznam.cz

**Culic Elektro Centar - Croatia**  
Tel: +38 5 2120 4333  
Mail: veleprodaja@culic.net

**EFA Elektro - Norway**  
Tel: +47 6681 2400  
Mail: post@efa.no

**Elektra-Bree-Bordenbouw - Belgium**  
Tel: +32 8941 0041  
Mail: kg@ebbnv.be

**ELSTEEL IRL - Republic of Ireland**  
Tel: +353 1 456 8566  
Mail: debbie@elsteel.ie

**ELSTEEL NI - Northern Ireland**  
Tel: +44 289 077 4041  
Mail: ghavlin@parkelect.co.uk

**ELSTEEL - Poland**  
Tel: +48 77 465 4666  
Mail: poland@elsteel.com

**ELSTEEL UK - United Kingdom**  
Tel: +44 197 885 5909  
Mail: sales@elsteel.co.uk

**Montakon - Netherlands**  
Tel: +31 73 599 6000  
Mail: info@montakon.nl

**N. N. Control Panels - Cyprus**  
Tel: +357 25 71 4816  
Mail: info@nncontrolpanels.com

**Rafmidlun - Iceland**  
Tel: +354 540 3500  
Mail: kolbeinn@rafmidlun.is

## EUROPE Contd.

**RS Components - England**  
Tel: +44 1536 20 1234  
Web: www.rswww.com

**UAB Electric Box - Lithuania**  
Tel: +370 68 697 304  
Mail: saulius@electricbox.lt

## CANADA

**Westshore Controls - Canada**  
Tel: +1 604 817 0987  
Mail: westshorecontrols@gmail.com

## AUSTRALIA

**IPD - Australia & New Zealand**  
Tel: +61 2 9645 0777  
Mail: brian.rodricks@ipdgroup.com.au

## MIDDLE EAST

**Base Control Tech - UAE**  
Tel: +971 6 557 9958  
Mail: vijayababu@basecontroltech.com

**Jaidah Electrical - Qatar**  
Tel: ++974 4463 8777  
Mail: sadek@jaidah.com.qa

**National Electrical Industries - Oman**  
Tel: +968 2 445 4951  
Mail: tusharchavan@neioman.com

**PAC International - Qatar**  
Tel: +974 4450 6084  
Mail: mazen.harab@harbelectric.com

**Pacific Ocean - Sharjah**  
Tel: +971 653 45334  
Mail: henry@pacificocean.ae

**Power & Control - Dubai**  
Tel: +971 4 883 0391  
Mail: khalil@pnc-ae.com

**Schneider Electrical - Israel**  
Tel: +972 4 609 4433  
Mail: sagi@sche.co.il

## ASIA

**ELSTEEL - Sri Lanka**  
Tel: +94 11 225 2485  
Mail: elsteel@elsteel.com

**ELSTEEL - India**  
Tel: +91 832 661 1111  
Mail: india@elsteel.com

**ELSTEEL Techno - Singapore & Malaysia**  
Tel: +65 645 546 98  
Mail: elsteel@singnet.com.sg

**Fudo Automation - Hydrabad, India**  
Tel: +91 40 2004 0814  
Mail: fudo@rediffmail.com

**Prakticheskaya Electrotehnica - Kazakhstan**  
Tel: +7 727 3783 294  
Mail: pealmaty@mail.ru

**Venora Lanka Power Panels - Sri Lanka**  
Tel: +94 11 248 9580  
Mail: venoralanka@venoragroup.com

## AFRICA

**ATI Systems - South Africa**  
Tel: +27 11 383 8300  
Mail: sales@atisystems.co.za

**M & E Commercial Engineers - Mauritius**  
Tel: +230 677 9838  
Mail: mec.eng@intnet.mu

**Specialised Power Systems - Kenya**  
Tel: +254 20 207 7219  
Mail: info@spsafrica.com

## CIS

**JSC Electronmash - Russia**  
Tel: +781 2 702 1262, Int 8000  
Mail: sales@ru.elsteel.com